

# MOTOR DISPENSER

# X2 STANDARD SMALL

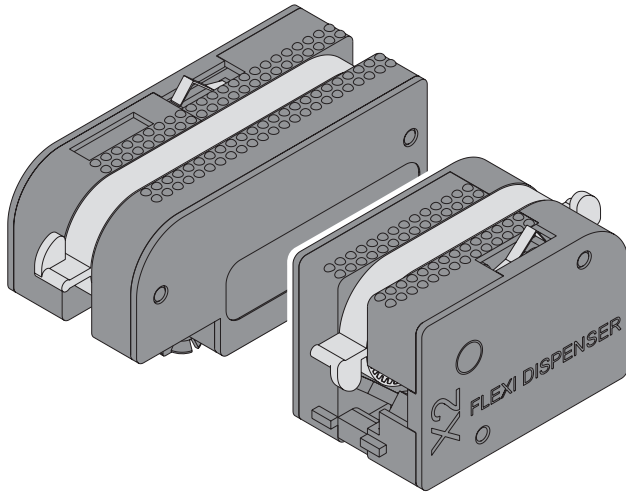

A.U.S. SPIELGERÄTE GMBH  
SCHEYDGASSE 48, AT 1210 WIEN  
☎ +43 (0) 1 271 66 00 65 FAX +43 (0) 1 271 66 00 75  
🌐 www.aus.at ✉ verkauf@aus.at





## INDEX

### 1 GENERAL INFORMATION

- 1.1 GENERALITIES
- 1.2 VERSIONS
- 1.3 DIMENSIONS
- 1.4 TECHNICAL DATA
- 1.5 CONDITIONS FOR USE

### 2 OPERATION

- 2.1 ON SELF HOLD
- 2.2 DIRECT CONTROL (HIGH SIDE SWITCH)
- 2.3 DIRECT CONTROL (LOW SIDE SWITCH)
- 2.4 MANAGING PRODUCT PRESENCE SWITCH
- 2.5 STOP PRODUCT POSITION
  - 2.5.1 SW3 Switch
  - 2.5.1 SW4 Switch
- 2.6 GAMMA MODELS
- 2.7 CC TALK SUPPORTED COMMANDS
- 2.8 TABLE FOR ORDERS

### 3 SPARE PARTS

# 1 GENERAL INFORMATION

## 1.1 GENERALITIES

The **X2** motor dispenser is available in two new versions, adaptable to various needs as far as available space inside the machines, and can be used in multiple applications in automatic product and prize drawing distributors. Its versatility makes it simple to connect and install on any type of machine.

## 1.2 VERSIONS

Two versions of the **X2** motor dispenser are available:

**STANDARD**

**SMALL**

## 1.3 DIMENSIONS

Files in 3d format can be requested at [sales@aus.at](mailto:sales@aus.at) for design purposes (for the various exportation extensions).

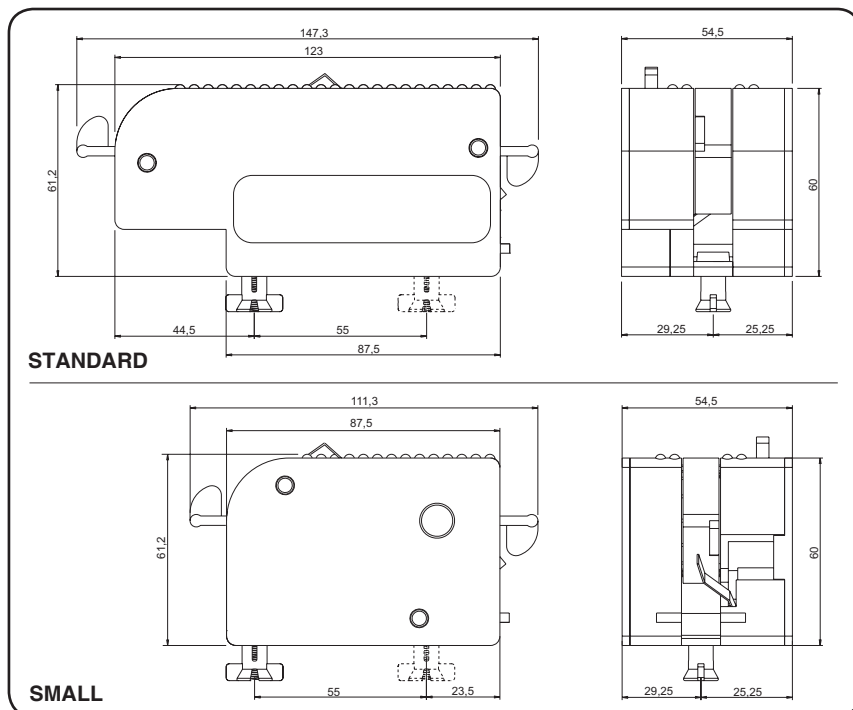

## 1.4 TECHNICAL DATA

Dispensing speed (STANDARD mod.)	3.5"
Dispensing speed (SMALL mod.)	2.4"
Power supply	12V dc $\pm$ 10%
Weight (STANDARD mod.)	254 gr
Weight (SMALL mod.)	217 gr

## 1.5 CONDITIONS FOR USE

For the **X2** motor dispenser to function properly it should be installed inside machines that conform to the following conditions for use

- **NOT EXPOSED TO DIRECT SUNLIGHT**
- **MINIMUM TEMPERATURE 0°C**
- **MAXIMUM TEMPERATURE 50°C**
- **RELATIVE HUMIDITY BETWEEN 50 AND 90%**

## 2 OPERATION

### 2.1 ON SELF HOLD

The grounded signal sent to the pin 6 for a minimum of 0.5 seconds starts dispensing the product.

At the end of the operation **X2** autonomously returns to its starting position, ready for the next dispensing.

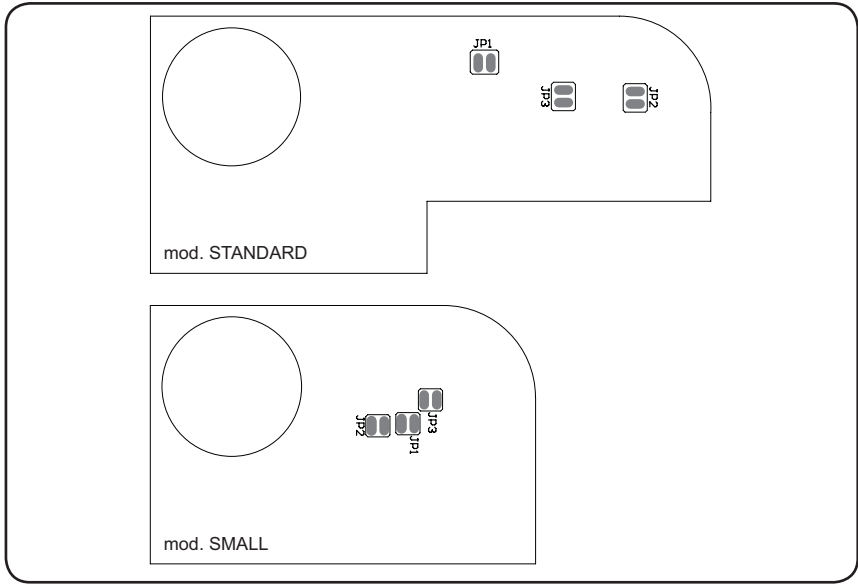

#### version A

**JP1 OPEN      JP2 CLOSED      JP3 CLOSED**

- 1 +12V dc
- 2 NC empty
- 3 NO empty
- 4 GND
- 5 GND
- 6 cycle working (GND)

#### version B

**JP1 OPEN      JP2 OPEN      JP3 OPEN**

- 1 +12V dc
- 2 NC empty
- 3 NO empty
- 4 -
- 5 GND
- 6 cycle working (GND)

## 2.2 DIRECT CONTROL (HIGH SIDE SWITCH)

The signal sent to +12V to pin 1 starts dispensing the product.

Dispensing can be de-activated by excluding the sending of this signal.

When the tape's flap passes the stop switch it transforms it into a position sensor, leading to the shortcircuiting of pin 4.

To electronically manage the signal we suggest using a pull-up.

At the end of the operation **X2** autonomously returns to the starting position, ready for the next dispensing.

### version C

	JP1 CLOSED	JP2 OPEN	JP3 CLOSED
1		MOTOR OPERATION +12V dc	
2		NC empty	
3		NO empty	
4		PRODUCT DISPENSING SIGNAL (GND)	
5		GND	
6		-	

## 2.3 DIRECT CONTROL (LOW SIDE SWITCH)

The ground signal sent to pin 6 starts dispensing the product.

Dispensing can be de-activated by excluding the sending of this signal.

When the tape's flap passes the stop switch it transforms it into a position sensor, leading to the shortcircuiting of pin 4.

To electronically manage the signal we suggest using a pull-up.

At the end of the operation **X2** autonomously returns to the starting position, ready for the next dispensing.

### version D

	JP1 OPEN	JP2 OPEN	JP3 OPEN
1		MOTOR OPERATION +12V dc	
2		NC empty	
3		NO empty	
4		PRODUCT DISPENSING SIGNAL (GND)	
5		GND	
6		-	

## 2.4 MANAGING PRODUCT PRESENCE SIGNAL

The energized SW1 sensor indicates the presence of product on the **X2** dispenser motion.

## 2.5 PRODUCT STOP POSITION

It is possible to set a stopping point for the product package on the **X2** by using the two switches, SW3 or SW4.

### 2.5.1 SW3 Switch

Enable the SW3 switch to stop the package at the beginning of the horizontal plane.

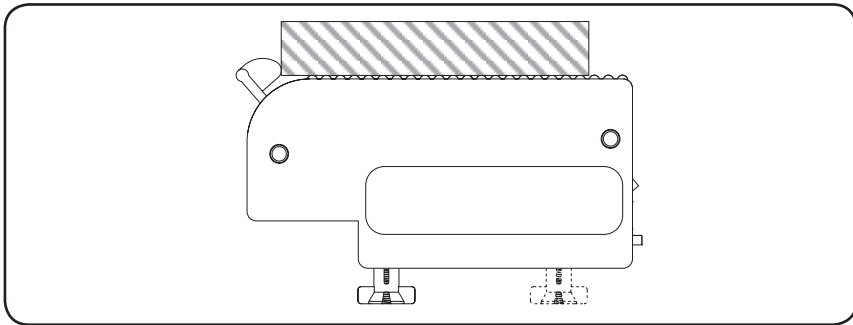

### 2.5.1 SW4 Switch

Enable the SW4 switch to stop the package at the end of the horizontal plane.

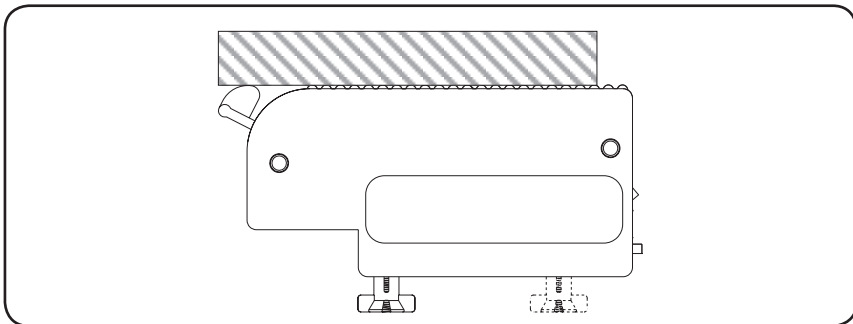



## 2.6 GAMMA MODELS

The drawings refer to the sheet.

**X2 STANDARD SD1X**

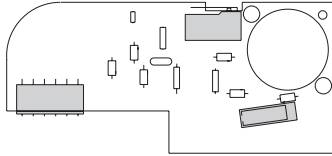

**X2 STANDARD SD1Y**

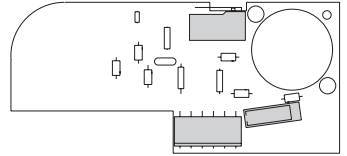

**X2 STANDARD SD2X**

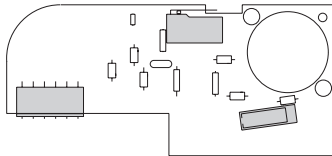

**X2 STANDARD SD2Y**

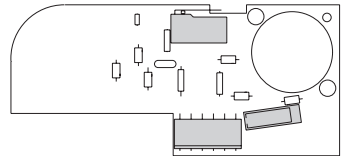

**X2 STANDARD SD3X**

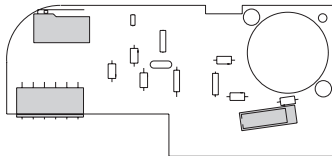

**X2 STANDARD SD3Y**

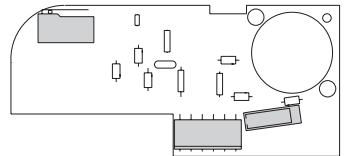

**X2 STANDARD SD4X**

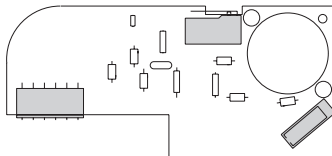

**X2 STANDARD SD4Y**

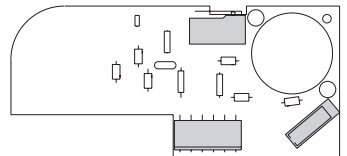

**X2 STANDARD SD5X**

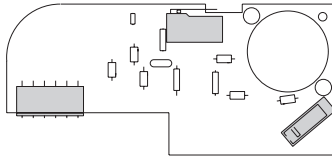

**X2 STANDARD SD5Y**

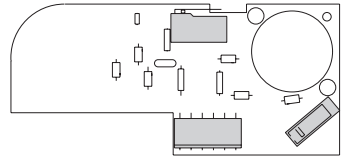

**X2 STANDARD SD6X**

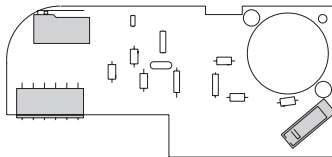

**X2 STANDARD SD6Y**

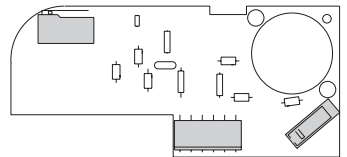

**X2 SMALL SM1X**

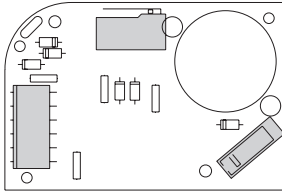

**X2 SMALL SM1Y**

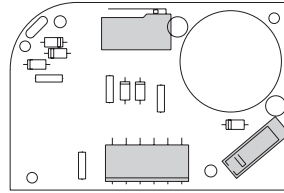

**X2 SMALL SM2X**

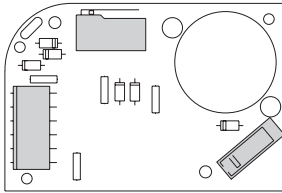

**X2 SMALL SM2Y**

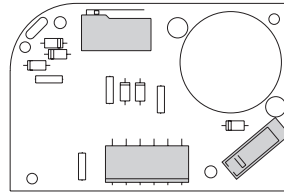

**X2 SMALL SM3X**

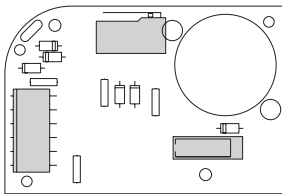

**X2 SMALL SM3Y**

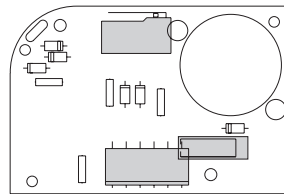

**X2 SMALL SM4X**

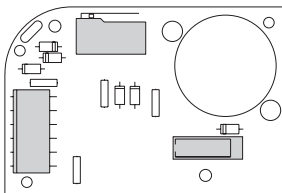

**X2 SMALL SM4Y**

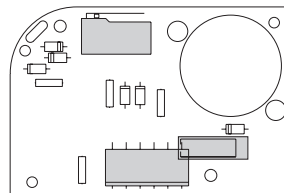



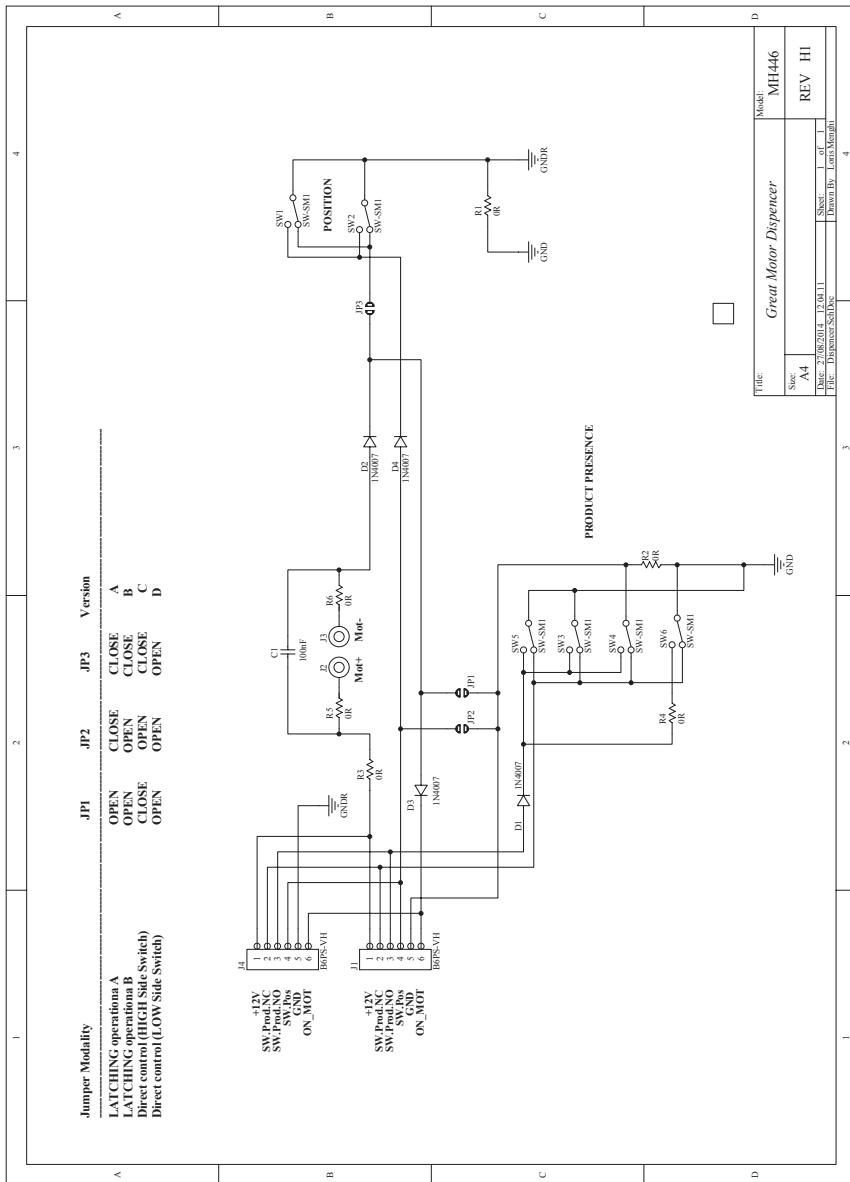

Title: <b>Great Motor Dispencer</b>		Block: <b>MH446</b>
Size: <b>A4</b>	Date: <b>27.08.2014_12.04.11</b>	Sheet: <b>of 1</b>
File: <b>Dispenser Schilbe</b>		Drawn By: <b>Levi Menghi</b>
REV <b>HI</b>		

## MH447 Connections:

Bottom view

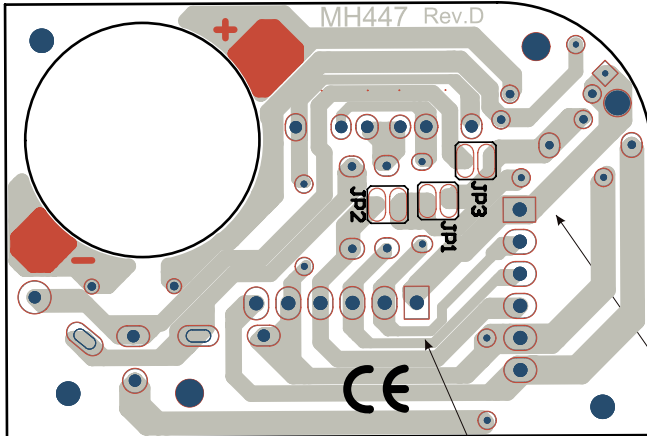

Top view

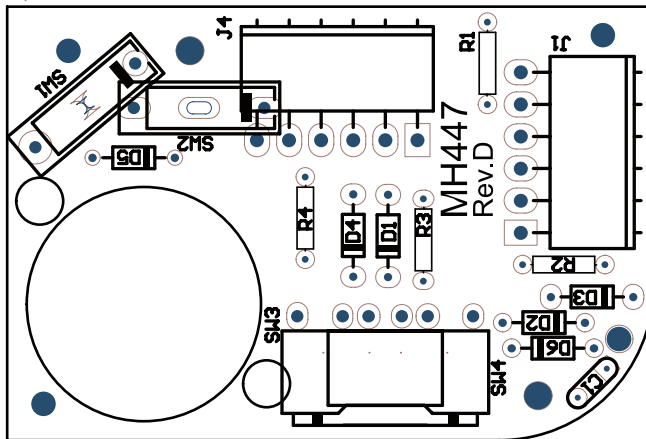

Connector of MotorDispenser step 3.96mm:

**JST:** cod. VHR-6N  
 Contact 20-16 AWG. cod.SVH-41T-P1.1

**Compatible ADIMPEX:** cod. J3962106  
 Contact 20-16 AWG. cod.J3962005

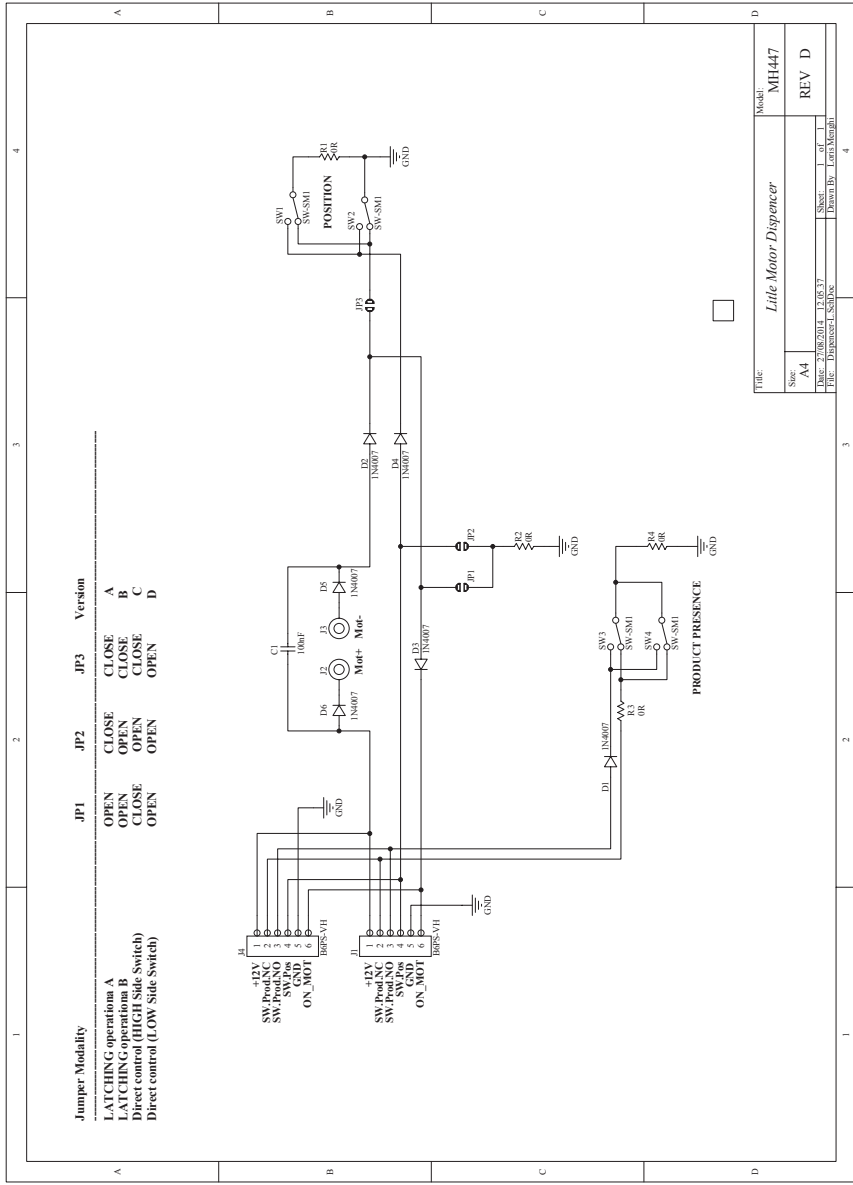

Title: <i>Lite Motor Dispenser</i>		Block: MH447
Size: A4	Date: 23.08.2014 12:06:37	Sheet: 1 of 1
File: Dispenser_E_Schiba		Drawn By: Lena Menghi



**X2 CC TALK CT1X**

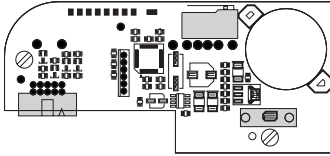

**X2 CC TALK CT1Y**

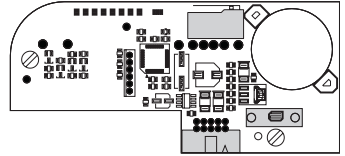

**X2 CC TALK CT2X**

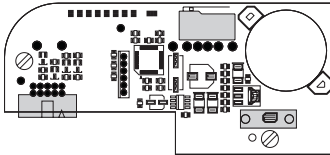

**X2 CC TALK CT2Y**

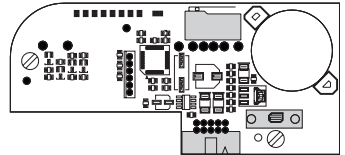

**X2 CC TALK CT3X**

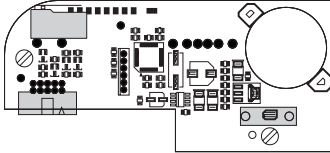

**X2 CC TALK CT3Y**

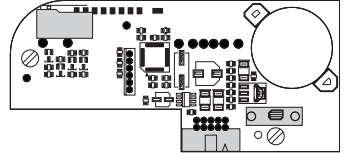

**X2 CC TALK CT4X**

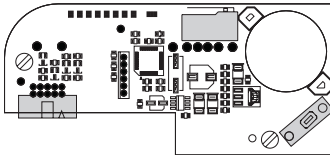

**X2 CC TALK CT4Y**

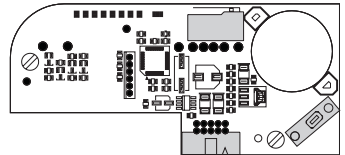

**X2 CC TALK CT5X**

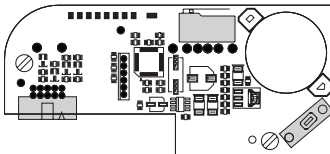

**X2 CC TALK CT5Y**

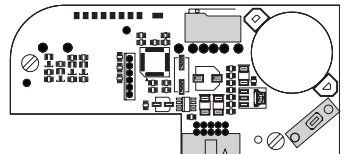

**X2 CC TALK CT6X**

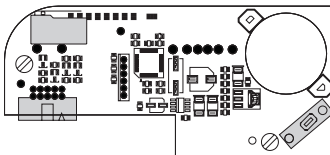

**X2 CC TALK CT6Y**

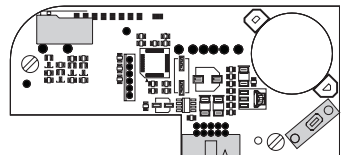

## 2.7 COMANDI SUPPORTATI CCTALK

### Flat 10 Pin Connector

<b>Pin 1</b>	- Data ccTalk
<b>Pin 2</b>	- n.c.
<b>Pin 3</b>	- n.c.
<b>Pin 4</b>	- Gnd
<b>Pin 5</b>	- n.c.
<b>Pin 6</b>	- n.c.
<b>Pin 7</b>	- +12V
<b>Pin 8</b>	- Gnd
<b>Pin 9</b>	- n.c.
<b>Pin 10</b>	- +12V

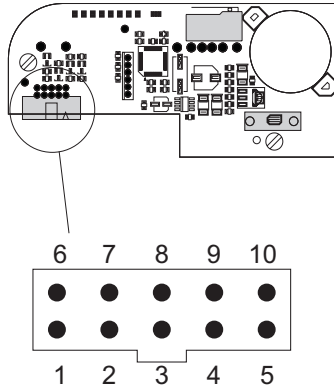

**Pin 1**                      data line  
**Pin 4 and Pin 8**        GND  
**Pin 7 and Pin 10**      +24

The remaining Pins are not connected.



Header 255	Factory set-up and test
Header 254	Simple poll
Header 253	Address poll
Header 252	Address clash
Header 251	Address change
Header 250	Address random
Header 247	Request variable set
Header 246	Request manufacturer id
Header 245	Request equipment category id
Header 244	Request product code
Header 242	Request serial number
Header 241	Request software revision
Header 236	Read opto states
Header 219	Enter new PIN number
Header 218	Enter PIN number
Header 217	Request payout high / low status
Header 216	Request data storage availability
Header 215	Read data block
Header 214	Write data block
Header 192	Request build code
Header 172	Emergency stop
Header 171	Request hopper coin
Header 169	Request address mode
Header 168	Request hopper dispense count
Header 167	Dispense hopper coins
Header 166	Request hopper status
Header 165	Modify variable set
Header 164	Enable hopper
Header 163	Test hopper
	Flag Explanation
	Absolute maximum current exceeded
	Payout timeout occurred
	Motor reversed during last payout to clear a jam
	Opto fraud attempt, path blocked during idle
	Opto fraud attempt, short-circuit during idle
	Opto blocked permanently during payout
	Power-up detected
	Payout disabled
	Opto fraud attempt, short-circuit during payout
	Single coin mode
	PIN number mechanism
Header 161	Pump RNG
Header 160	Request cipher key
Header 4	Request comms revision
Header 3	Clear comms status variables
Header 2	Request comms status variables
Header 1	Reset device

## Header 251 address change

With this command the ccTalk address can be changed at will and in a non-volatile way. If address 0 or 1 is selected, the command is ignored; the address is 3 by default.

The ccTalk address can also be changed in hardware mode on the printed circuit called "A0-A7" (from address 0 to address 255):

jumper open = 0 (default)

jumper closed = 1

If address 0 (default - all jumpers open) or address 1 is selected via the jumpers, software addressing mode is selected.

## Dispense command

The dispense command accepts quantity 1 only; therefore only one product may be dispensed for each dispense command. If an attempt is made to dispense more than one product with a single dispense command, the motor dispenser responds with a "NAK" signal.

## 2.8 TABLE FOR ORDERS

 To request new products fill out the table below depending on the various combinations possible (see chapter 2), indicating the quantity desired in the relative box.

Requests with missing information will not be taken into consideration.

Send copy/ies by fax to number +43 1 2716600 75

### NEW PRODUCT REQUEST FORM Send copy to fax nr +43 1 271 66 00 75

#### CUSTOMER INFORMATION

Company name \_\_\_\_\_

Address \_\_\_\_\_ Date of request \_\_\_\_\_

City \_\_\_\_\_

tel. \_\_\_\_\_ Stamp/Signature \_\_\_\_\_

fax \_\_\_\_\_

MODEL SERIES X	JUMPER VERSION			
	vers. A q.ty	vers. B q.ty	vers. C q.ty	vers. D q.ty
SD1X				
SD2X				
SD3X				
SD4X				
SD5X				
SD6X				
SM1X				
SM2X				
SM3X				
SM4X				
MODEL SERIES X	CC TALK VERSION			
	q.ty	q.ty	q.ty	q.ty
CT1X				
CT2X				
CT3X				
CT4X				
CT5X				
CT6X				

MODEL SERIES Y	JUMPER VERSION			
	vers. A q.ty	vers. B q.ty	vers. C q.ty	vers. D q.ty
SD1Y				
SD2Y				
SD3Y				
SD4Y				
SD5Y				
SD6Y				
SM1Y				
SM2Y				
SM3Y				
SM4Y				
MODEL SERIES Y	CC TALK VERSION			
	q.ty	q.ty	q.ty	q.ty
CT1Y				
CT2Y				
CT3Y				
CT4Y				
CT5Y				
CT6Y				

### 3 SPARE PARTS

 To replace parts use exclusively original spare parts.

 Use of non-original and/or non-regulation spare parts (if not authorized in writing exclusively by the customer service center) releases the manufacturer from any liability whatsoever.

To request spare parts photocopy the pertinent page of the spare parts table and fill out completely the table, indicating the table containing the part, its reference number on the drawing and the quantity of parts required, and your personal information.

Incomplete requests will not be taken into consideration.

### SPARE PARTS REQUEST FORM

Send copy to fax nr 0043 1 271 66 00 75

#### CUSTOMER INFORMATION

Company name \_\_\_\_\_

Address \_\_\_\_\_ Date of request \_\_\_\_\_

City \_\_\_\_\_

tel. \_\_\_\_\_ Stamp/Signature \_\_\_\_\_

fax \_\_\_\_\_

TAB.	N.	Q.TY

TAB.	N.	Q.TY

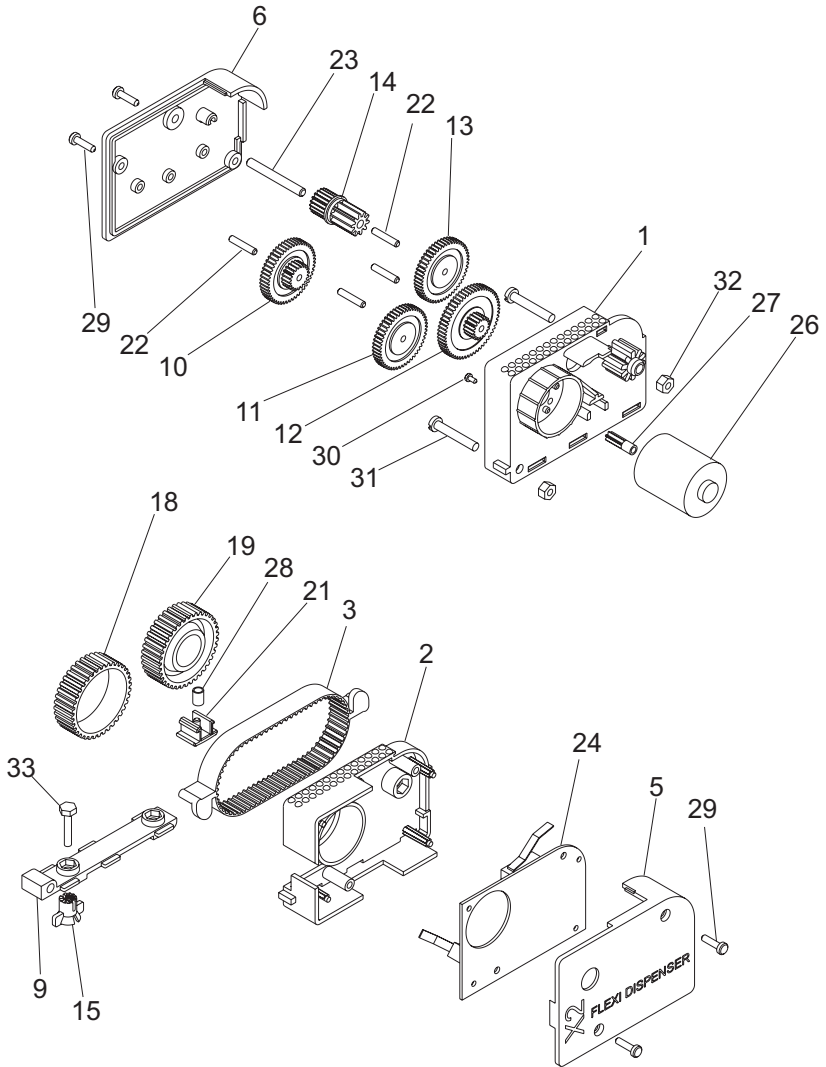

**TABLE. 1 - X2 SMALL**

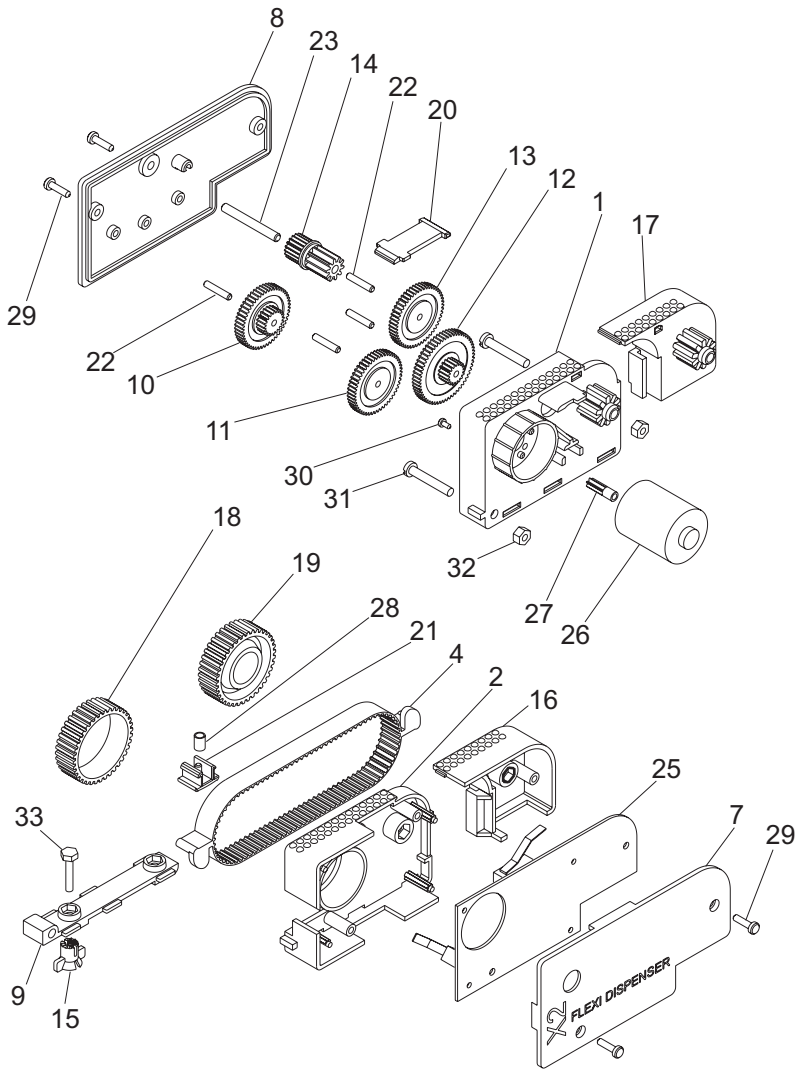

**TABLE. 2 - X2 STANDARD**



**A.u.S. Spielgeräte GmbH**  
**Scheydgasse 48 - A-1210 Wien**  
**TEL.: 0043 1 271 66 00 FAX: 0043 1 271 66 00 75**  
**info@aus.at**  
**www.aus.at**